

## Welcome to the thingSoC® Teensy3x Adapter Board

The **TSOC\_Teensy3x** is an adapter for the excellent [Teensy Development Board](#) from [PJRC](#).

The **TSOC\_Teensy3x** allows you to connect [thingSoC](#) , [Mikrobus](#) , and/or [Grove System](#) Modules all at the same time, either standalone, or with any other thingSoC Processor or Radio module. This gives you maximum flexibility for sensor and actuator selection and reuse.

### Assembling the TSOC\_Teensy3x :

If you have purchased just the adapter board by itself, you will need to do a little soldering to assemble the unit. The TSOC\_Teensy3x was designed using easy to solder through-hole components, so it would be simple to assemble for even the most inexperienced user.

1) The bare board (version 2.0) is shown below :



2) First, insert the "Grove" connectors, flip the board over and solder them securely.



3) Next insert the twelve (12) pin female headers, flip the board over and solder them securely.

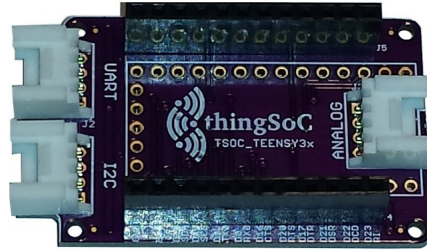

4) Then insert the male pins into the Teensy outline. MAKE SURE to put the "short side" down into the holes, and the "long side" of the pins on the top side, so that the Teensy has enough space to clear the "grove" connectors, as shown, and solder them securely.



5) Finally, attach the Teensy3.2 board, and solder it securely from the top side, as shown :

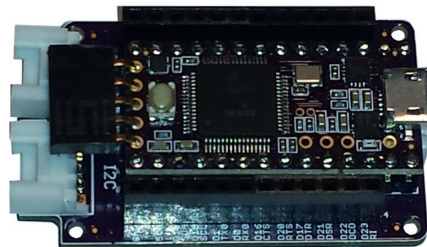

## Download and Install Teensyduino :

Teensyduino is a software add-on for the [Arduino IDE](#), developed for the Teensy by [PJRC](#).

1) Download and install the Arduino IDE from :

<https://www.arduino.cc/en/Main/Software>

2) Download and install the Teensyduino package :

[https://www.pjrc.com/teensy/td\\_download.html](https://www.pjrc.com/teensy/td_download.html)

3) Run the Teensyduino Installer :

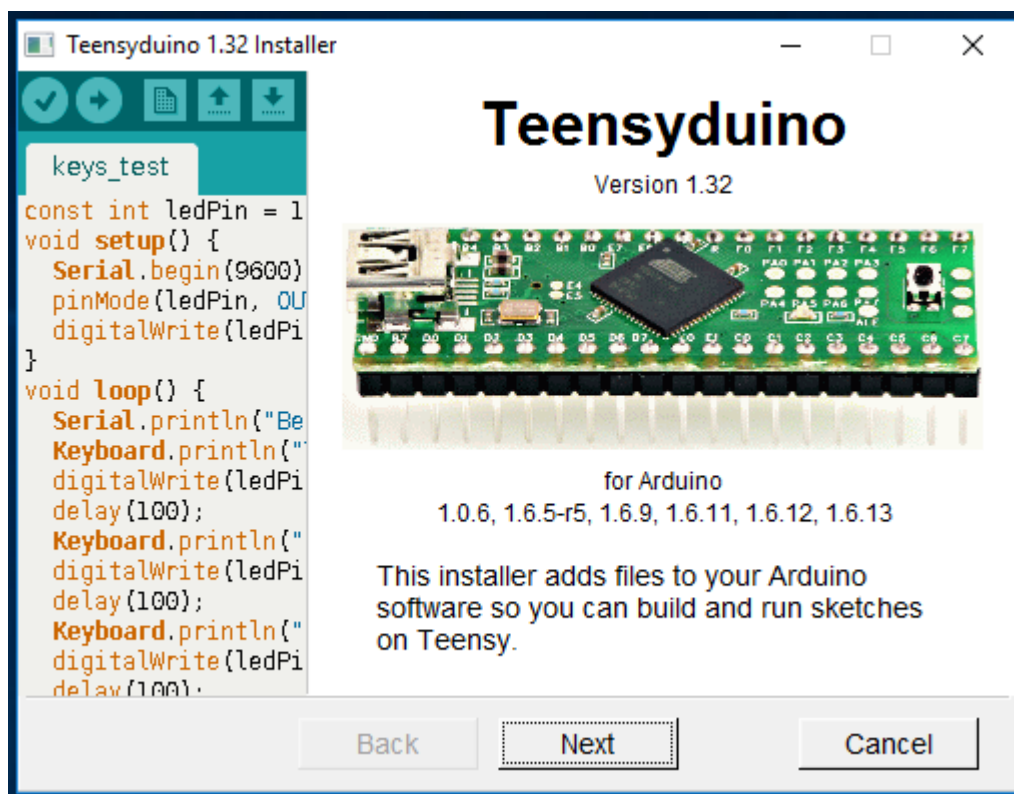

4) When using Arduino, be sure to select Teensy in the Tools > Boards menu.

Arduino's File > Examples menu automatically changes to show the libraries and examples for the selected board.

## Getting Started :

- 1) Using a USB-Micro cable, plug the TSOC\_Teensy3x board into your Windows, MAC, or Linux PC.
- 2) The drivers should be found automatically on most systems.  
However if they are not, they can be downloaded from :  
[https://www.pjrc.com/teensy/td\\_download.html](https://www.pjrc.com/teensy/td_download.html)

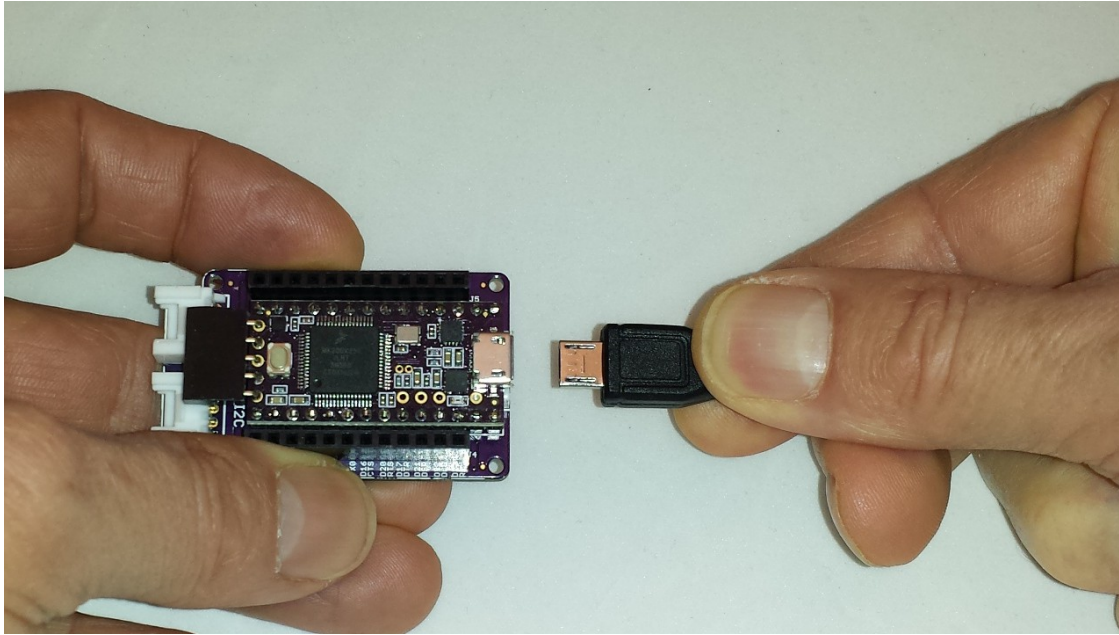

- 3) With the default firmware, when the TSOC\_Teensy3x board is first connected to power, the onboard LED will begin to blink slowly.

## Safe Handling Precautions :

- 1) Always remove/unplug all power before inserting or removing peripherals.
- 2) Always ground yourself by touching a ground point before handling your boards.
- 3) Use a static safe bag when transporting your TSOC\_Teensy3x board.



## Supported Peripherals :

The TSOC\_Teensy3x board supports thingSoC, Grove, and Mikrobus peripherals.



## Attaching Mikrobus Peripherals :

- 1) Any 3.3 Volt compatible [Mikrobus peripheral](#) may be directly connected to the TSOC\_Teensy3x.
- 2) **Make sure to align the SQUARE/CUT edges** of the boards together to insure that the polarity is correct. Push down **evenly** to seat the boards in the socket.
- 3) Note that the "stacking pins" are somewhat longer by design, and there will be some extra space between the boards when using stacking connectors.
- 4) Note that Mikrobus is only sixteen (16) pins while thingSoC is twenty-four (24) pins, make sure to align the smaller Mikrobus board to the back edge of the TSOC\_Teensy3x (i.e. Ground to Ground) as shown :

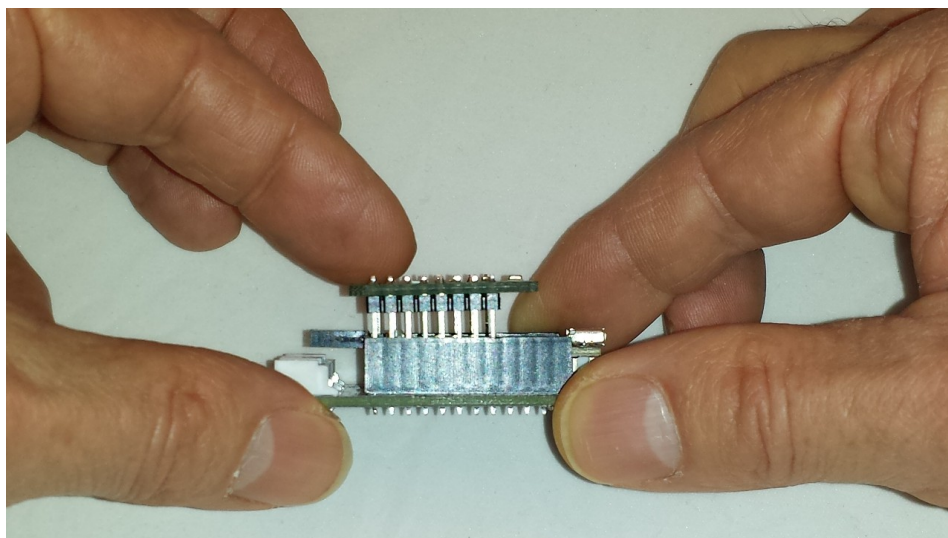
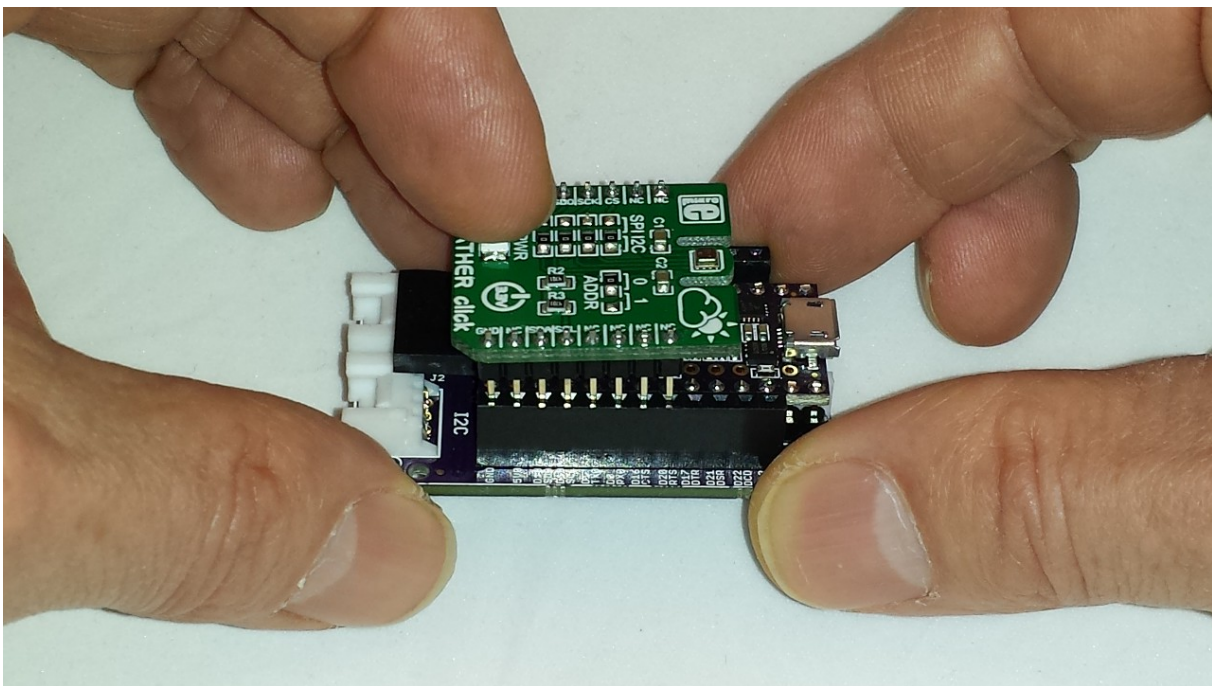

## MikroElektronika Click® Boards:

The TSOC\_Teensy3x is compatible with most 3.3 Volt Click® boards, available at Digikey, Mouser and from [Mikroelektronika direct](#). There are already hundreds of boards available to just plug in!

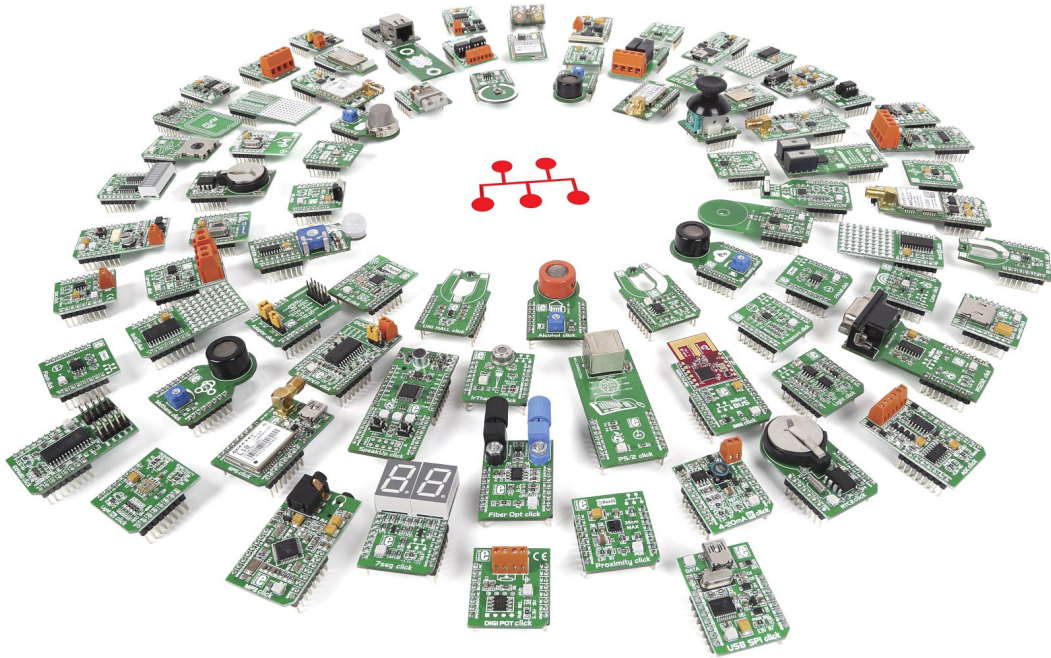

## Attaching Grove Peripherals :

- 1) As shown below, there are three(3) white "Grove" connectors, and they are named,  
UART - (Serial #3 , using Teensy3x pins D7 and D8 )  
I2C - (I2C #0, using Teensy3x pins D18 and D19 )  
ANALOG - (Using Teensy3x pins A0 and D9)

Note : All of these pins are connected directly to the Teensy and are 3.3 Volt levels only.  
Do Not connect 5.0 Volt peripherals to these pins, or you may damage your Teensy!  
(we have the thingSoC I2C Hub, GPIO, and ADC for connecting 5.0 Volt peripherals!)



2) Any 3.3 Volt compatible Grove peripheral may be connected directly to the TSOC\_Teensy3x, there are dozens of sensors and actuators available from the [Seedstudio Bazaar](#).

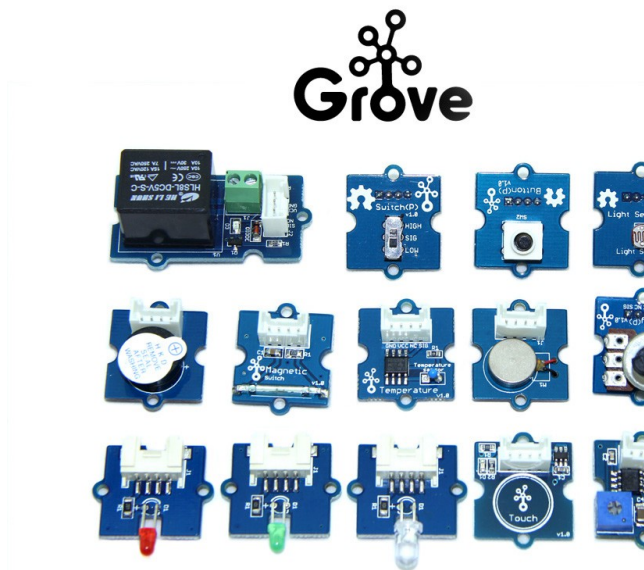

### Basement Water/Flooding Sensor and Pump Relay Example :

The example circuit shows a simple water sensor, with an audio buzzer output and a relay control to activate a water pump.

When water is detected by the sensor, the buzzer sounds and the relay engages to activate a water pump (not shown).

The code is available in the TSOC\_Teensy3x examples directory.

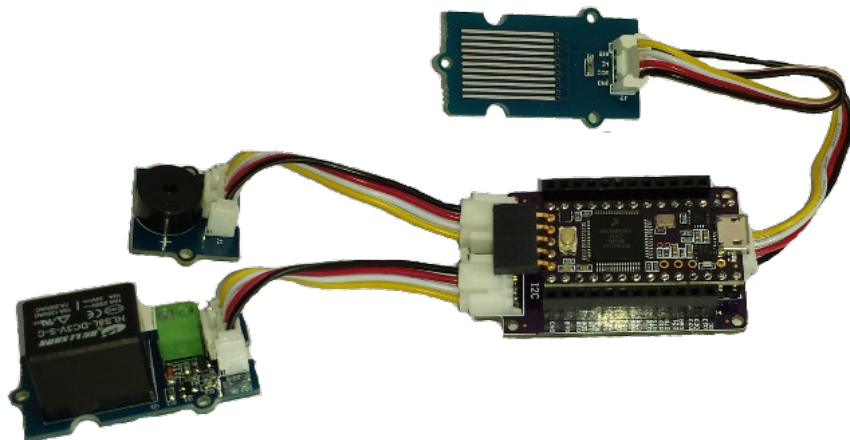



## Teensy 3.2 Features :

The TSOC\_Teensy3x is a low cost, embeddable module featuring a MK20DX256VLH7 device :

- 72/96 MHZ ARM Cortex-M4F Processor (Freescale)
- USB Full-Speed Controller
- 256K Bytes Flash Memory
- 64K bytes RAM Memory
- 2048 bytes EEPROM memory
- Serial Communication (3 Ports)
- Counter/Timers/PWMs (12)
- CAN (controller area network) Controller
- I2C controllers (2)
- USER LED
- USER Pushbutton
- [thingSoC Compliant Module](#)
- [Mikrobus Compatible Module](#)

Top Side :

(From <https://www.pjrc.com/teensy/pinout.html> )

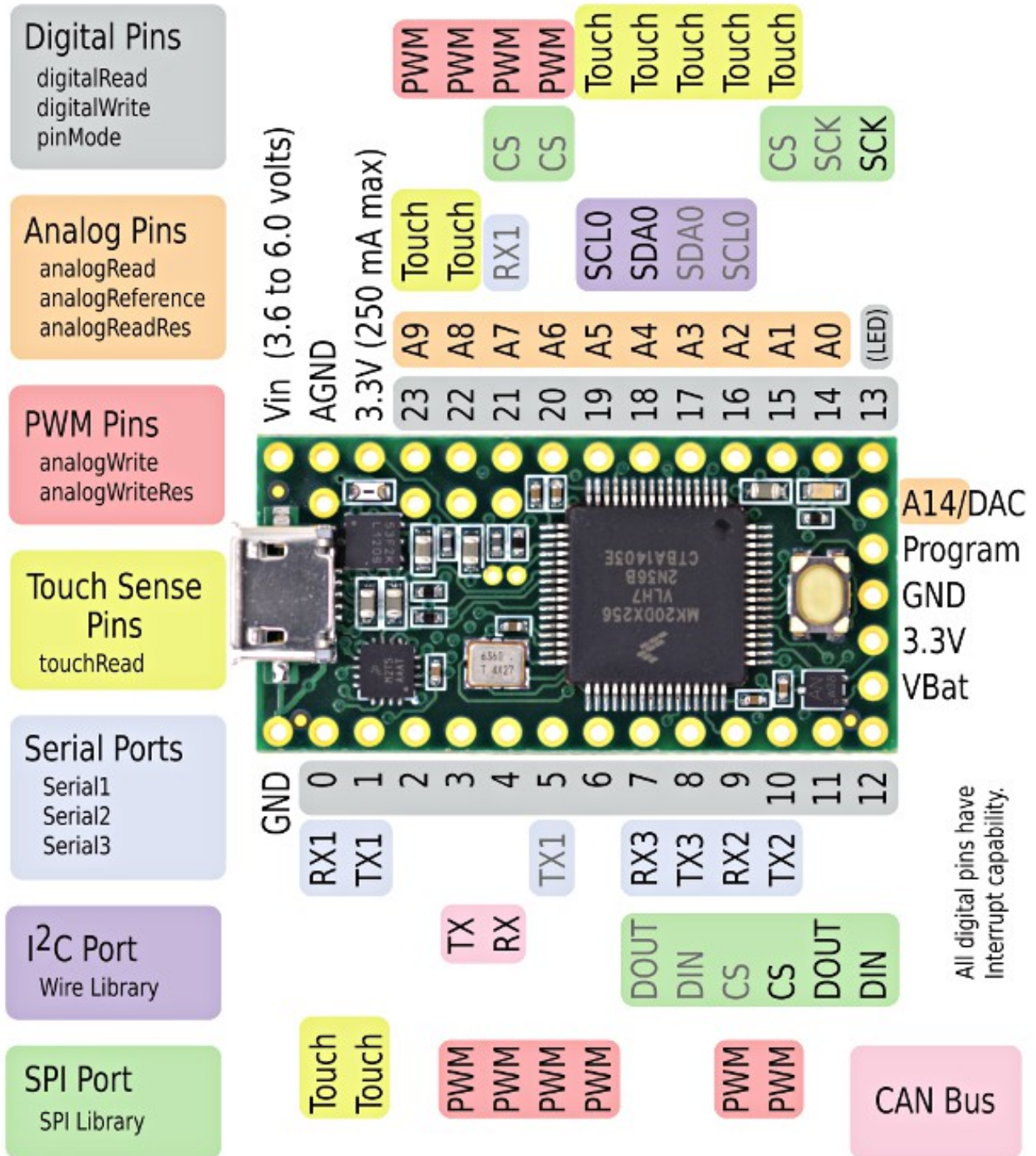

Rear Side :

(From <https://www.pjrc.com/teensy/pinout.html> )

